

## Table of Contents

Sq.	Title	Page
1.0	Introduction.....	2
1.1	Objective.....	2
1.2	Control Loop.....	2
2.0	Control Components.....	4
2.1	Power Relays.....	4
2.2	Motor start relays.....	5
2.3	Relays with more than one contact.....	6
2.4	Thermal overload protectors.....	7
2.5	Time-delay relays.....	8
2.6	Solenoids.....	10
2.7	Thermostats.....	11
2.8	Bellows-type thermostats.....	11
2.9	Bimetallic-type thermostats.....	13
2.10	Heating and cooling thermostats.....	14
2.11	Microprocessor thermostats.....	18
2.12	Thermostat Adjustments.....	18
2.13	Heat anticipators.....	19
2.14	Cold anticipators.....	19
2.15	Switches of Many Types.....	20
2.16	Pressure Control Switches.....	21
2.17	Water Tower Controls.....	23
	References.....	26

## 1. INTRODUCTION

Automatic HVAC<sup>1</sup> control systems are designed to maintain temperature, humidity, pressure, flow, power, lighting levels, and safe levels of indoor contaminants. Automatic control primarily modulates, stages, or sequences mechanical and electrical equipment to meet load requirements and provide safe operation of the equipment. Control of HVAC systems also includes starting and stopping electric motors for fans, compressors, boilers, pumps, and accessories.

It can use digital, pneumatic, mechanical, electrical, and electric control devices, and implies that human intervention is limited in starting and stopping equipment and adjusting control set points.

Properly applied, automatic controls ensure that a correctly designed HVAC system will maintain a comfortable environment and perform economically over a wide range of operating conditions.

### 1.1 Objective

To achieve satisfied indoor environment by operating HVAC system this paper identifies the electrical control components for HVAC system in building.

### 1.2 Control Loop

A control loop can be represented in the form of a block diagram, in which each component of the control loop is modeled and represented in its own block (Figure 1). The flow of information from one component to the next is shown by lines between the blocks. The figure shows the set point being compared to the controlled variable. This difference, or offset error, is fed into the controller, which sends a control signal to the controlled device. In this case, the controlled device is a valve. The valve can change the amount of steam flow through the coil of Figure 1. The amount of steam flow is the input to the next block, which represents the process.

---

<sup>1</sup>Heating Ventilation and Air Conditioning

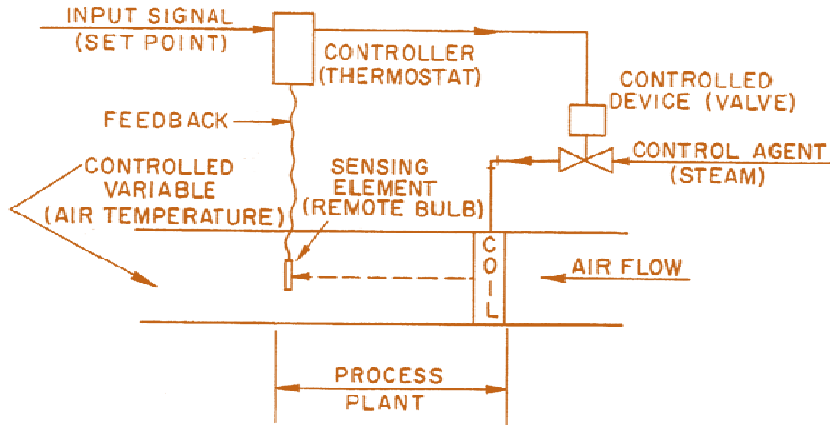

Fig. 1 Discharge Air Temperature Control (Example of Feedback Control)

From the process block comes the controlled variable, which is temperature. The controlled variable is sensed by the sensing element and fed to the controller as feedback, completing the loop. Each component of Figure 1 can be represented by a transfer function, which is an idealized mathematical representation of the relationship between the input and the output variables of the component. The transfer function must be sufficiently detailed to cover both the dynamic and static characteristics of the device. The dynamics of the component are represented in the time domain by a differential equation. In environmental control, the transfer function of many of the components can be adequately described by a first order differential equation, implying that the dynamic behavior is dominated by a single capacitance factor.

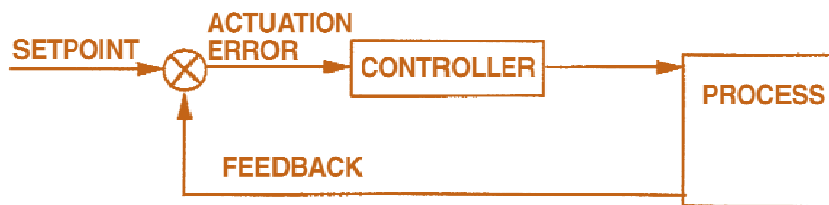

Fig. 2 Block Diagram of Discharge Air Temperature Control

For better understanding Table 1 shows the functions of control loops in central HVAC system.

Table 1. Functions of Central HVAC Control Loops.

Control Loop	Classification	Description
Ventilation	Basic	Coordinates operation of the outdoor, return, and exhaust air dampers to maintain the proper amount of ventilation air. Low-temperature protection is often required.
	Better	Measures and controls the volume of outdoor air to provide the proper mix of outdoor and return air under varying indoor conditions (essential in variable air volume systems). Low-temperature protection may be required.
Cooling	Chiller control	Maintains chiller discharge water at preset temperature or resets temperature according to demand.
	Cooling tower control	Controls cooling tower fans to provide the coolest water practical under existing wet bulb temperature conditions.
	Water coil control	Adjusts chilled water flow to maintain temperature.
	Direct expansion (DX) system control	Cycles compressor or DX coil solenoid valves to maintain temperature. If compressor is unloading type, cylinders are unloaded as required to maintain temperature.
Fan	Basic	Turns on supply and return fans during occupied periods and cycles them as required during unoccupied periods.
	Better	Adjusts fan volumes to maintain proper duct and space pressures. Reduces system operating cost and improves performance (essential for variable air volume systems).
Heating	Coil control	Adjusts water or steam flow or electric heat to maintain temperature.
	Boiler control	Operates burner to maintain proper discharge steam pressure or water temperature. For maximum efficiency in a hot water system, water temperature should be reset as a function of demand or outdoor temperature.

## 2. CONTROL COMPONENTS

### 2.1 Power Relays

One of these controls is the power relay. It is one of the most often used controls for controlling compressors in refrigeration and air conditioning. The power relay is also referred to as the *main conductor*. It is used to apply the main line voltage to the motor circuit. The coil of the relay is usually operated by voltages lower than the line provides. This means that it uses a transformer for the lower control voltages. The symbols used for this type of relay are shown in Fig. 3. Magnetic contactors are normally used for starting polyphase motors, either squirrel cage or single phase.

Contactors may be connected at any convenient point in the main circuit between the fuses and the motor. Small control wires (using low voltage) may be run between the contactor and the point of control.

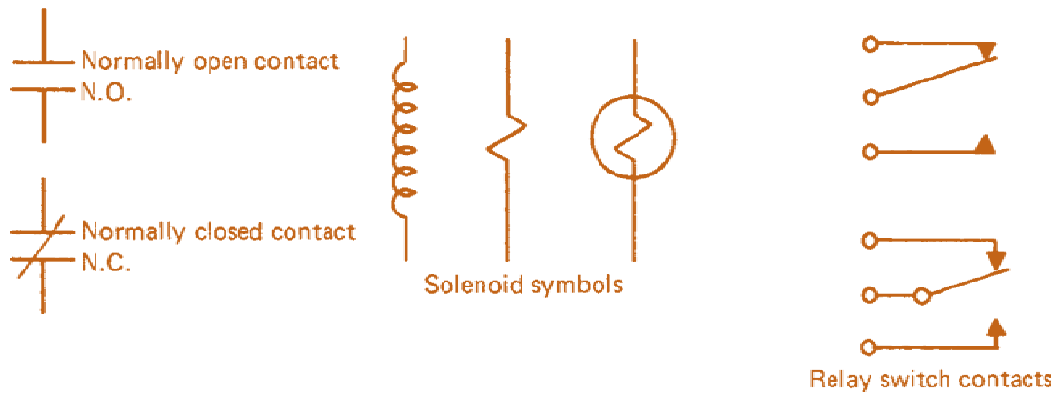

Figure 3: Symbols for the main contactor or power relay.

### 4.2 Motor start relays

Relays are a necessary part of many control and pilot-light circuits. They are similar in design to contactors, but are generally lighter in construction so they carry smaller currents. Compressors used for household refrigerators, freezers, dehumidifiers, vending machines, and water coolers have the capacitor-start, induction-run type of motor. This type of compressor may have a circuit that resembles Fig. 4. When the compressor is turned on by the thermostat demanding action, the relay is closed and the start winding is in the circuit. Once the motor comes up to about 90% of rated speed, there is enough current flow through the relay coil to cause it to energize, and it pulls the contacts of the relay open, thereby taking the start capacitor and start winding out of the circuit. This allows the motor to run with one winding as designed.

Figure 5 shows the current type of relay. This is generally used with small refrigeration compressors up to 3/4 horsepower. Figure 6 shows the potential type of relay. This is generally used with large commercial and air-conditioning compressors up to 5 horsepower.

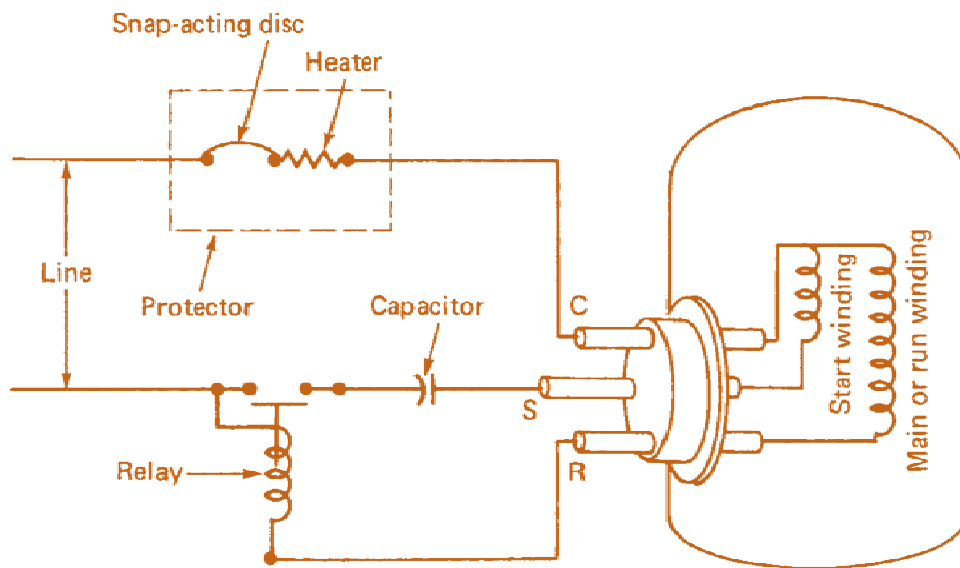

Figure 4: Capacitor-start, induction-run motor for a compressor with the potential relay used to take out the start winding once the motor comes up to speed.

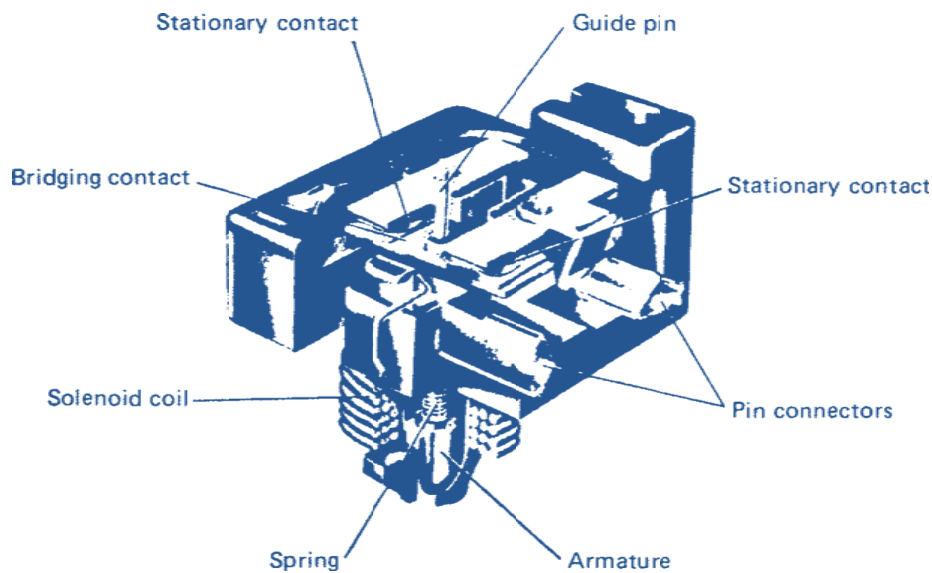

Figure 5: Current relay. (Courtesy of Tecumseh)

Protection of the motor against prolonged overload is accomplished by time limit overload relays. They are operative during the starting period and running period. Relay action is delayed long enough to take care of the heavy starting currents and momentary overloads without tripping.

### 2.3 Relays with more than one contact

Some power relays are made with more than one set of contacts. They are used to cause a sequence of events to take place. The contacts can be wired into a circuit that controls functions other than the on-off operation of the compressor motor (see Fig. 6).

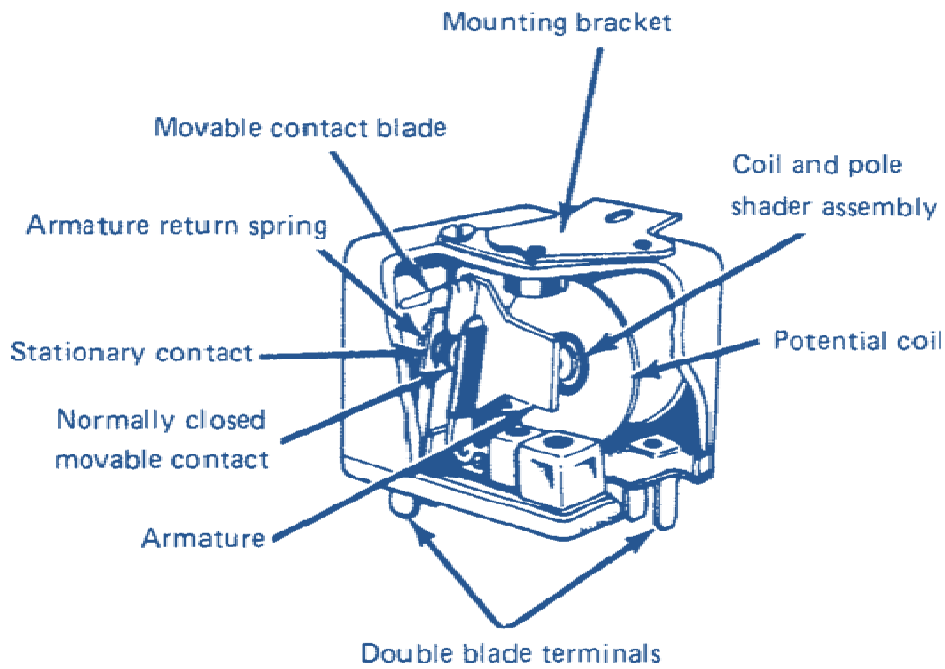

Figure 6: Potential relay. (Courtesy of Tecumseh)

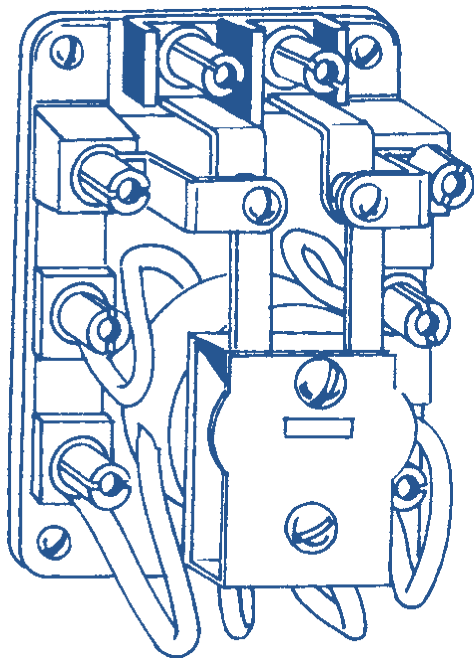

Figure 7: Relay with more than one set of contacts.

## 7.4 Thermal overload protectors

Motors for commercial units are protected by a bimetallic switch. The switch is operated on the heat principle. This is a built-in motor overload protector (see Fig. 8). It limits the motor winding temperature to a safe value. In its simplest form, the switch or motor protector consists essentially of a bimetal switch mechanism that is permanently mounted and connected in series with the motor circuit (see Fig. 9). Figure 10 shows how the external line-break overload operates.

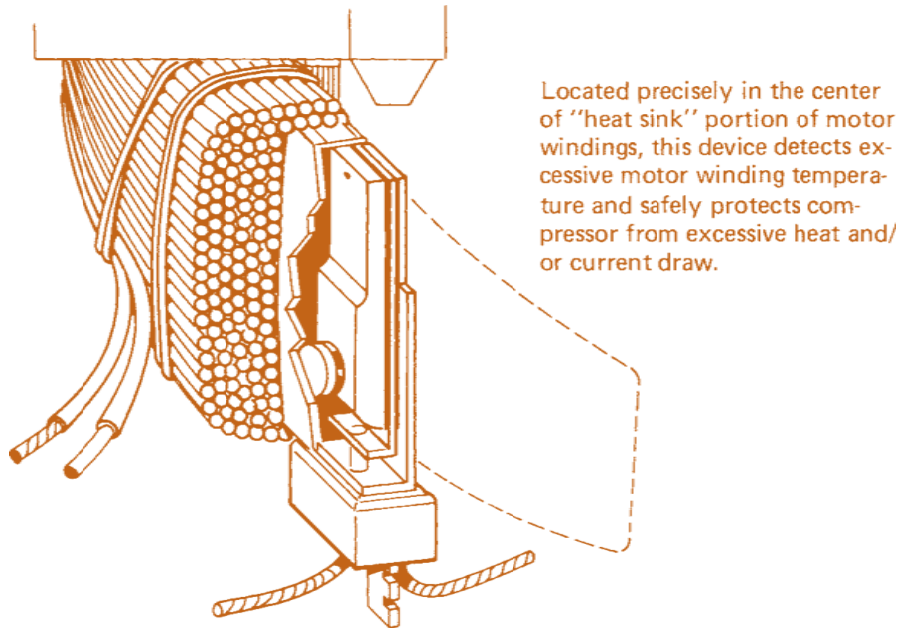

Figure 8: Motor protector inserted in the windings of the compressor. (Courtesy of Tecumseh)

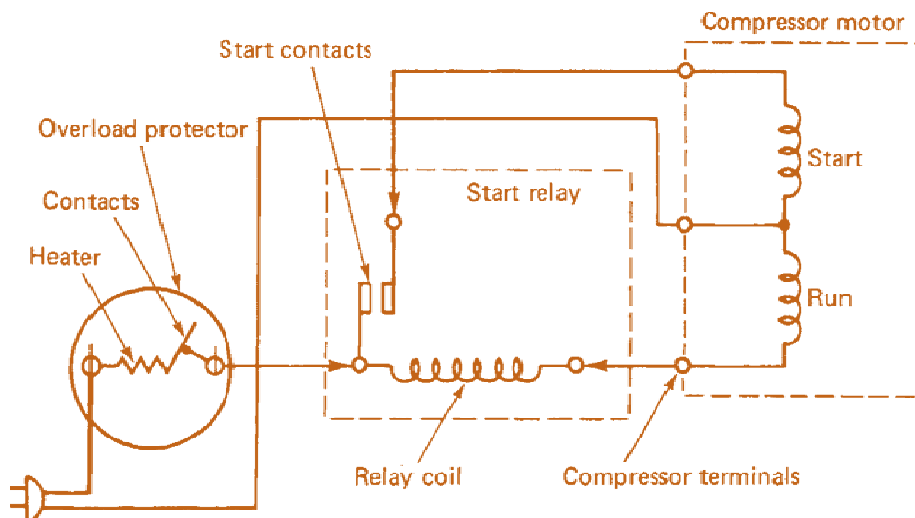

Figure 9: Domestic refrigerator circuit showing the start contacts and relay coil, as well as the overload protector.



## 2. Time-delay relays

In time-delay relays, bimetallic strips are heated with an electrical resistance mounted near or around them. The strips expand when heated. When they expand, they make contact and complete the circuit with their contacts closed (see Fig. 11). The time delay can be adjusted by the resistance of the heater unit. This type of unit is different from that shown as a protector in Fig. 9.

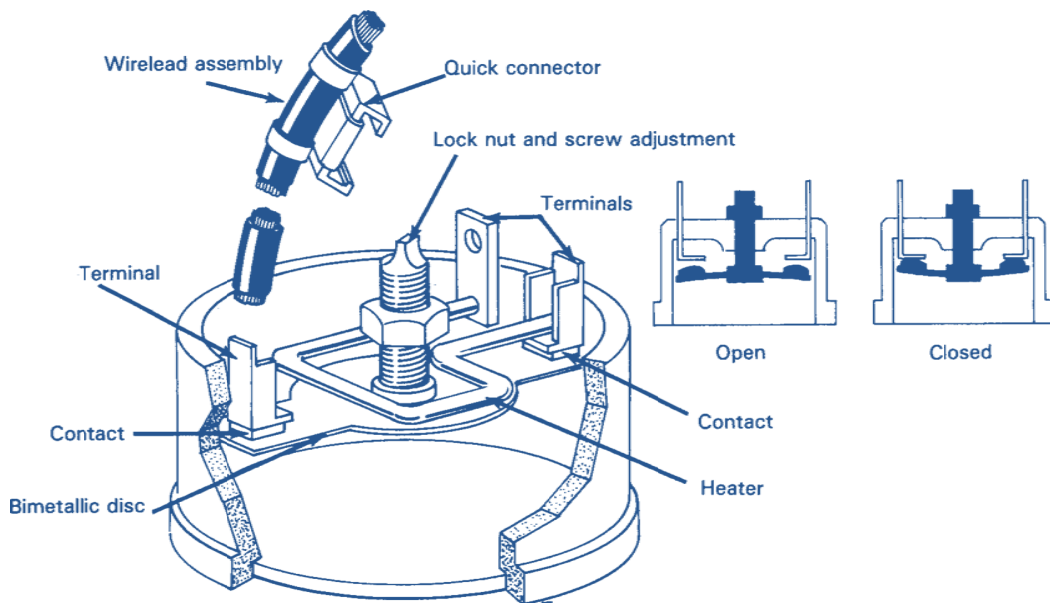

Figure 10: Externally located line-break overload. (Courtesy of Tecumseh)

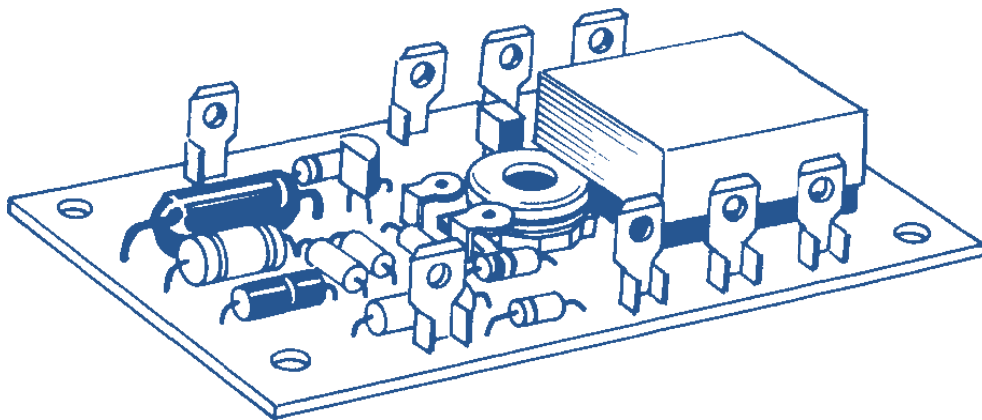

Figure 11: Time-delay relay.

The heating element in Fig. 9 causes the circuit to open and protect the motor. The time-delay relay is used to make sure that certain things take place within the refrigeration cycle before another is commenced.

## 2.6 Solenoids

Solenoid valves are used in many heating and cooling applications. They are electrically operated. A solenoid valve, when connected as in Fig. 12, remains open when current is supplied to it. It closes when the current is turned off. In general, solenoid valves are used to control the liquid refrigerant flow into the expansion valve or the refrigerant gas flow from the evaporator when it or the fixture it is controlling reaches the desired temperature. The most common application of the solenoid valve is in the liquid line, and it operates with a thermostat (see Fig. 13).

The solenoid shown in Fig. 14 controls the flow of natural gas in a hot-air furnace. Note how the coil is wound around the plunger. The plunger is the core of the solenoid. It has a tendency to be sucked into the coil whenever the coil is energized by current flowing through it. The electromagnetic effect causes the plunger to be attracted upward into the coil area. When the plunger is moved upward by the pull of the electromagnet, the soft disc is pulled upward, allowing gas to flow through the valve. This basic technique is used to control water, gasoline, oil, or any other liquid or gas.

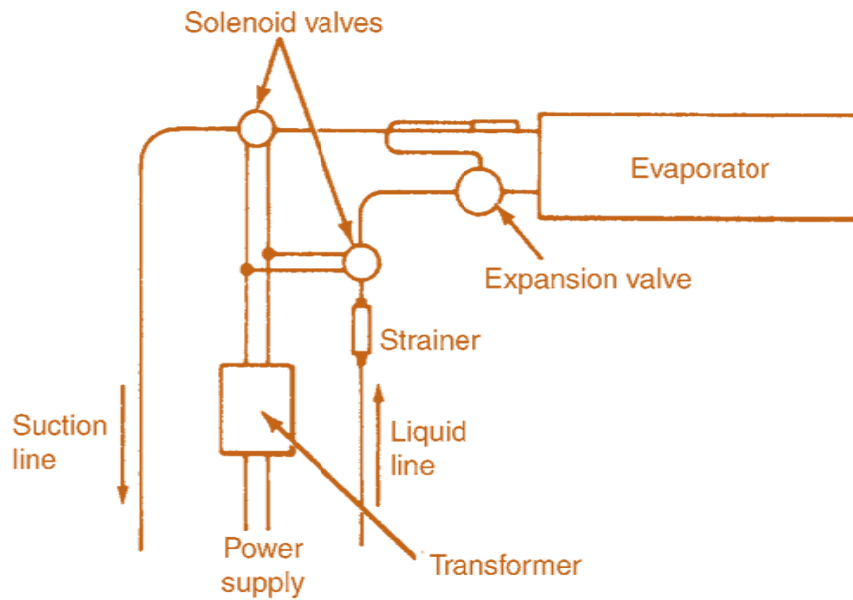

Figure 12: Solenoid valves connected in the suction and liquid evaporator lines of a refrigeration system.

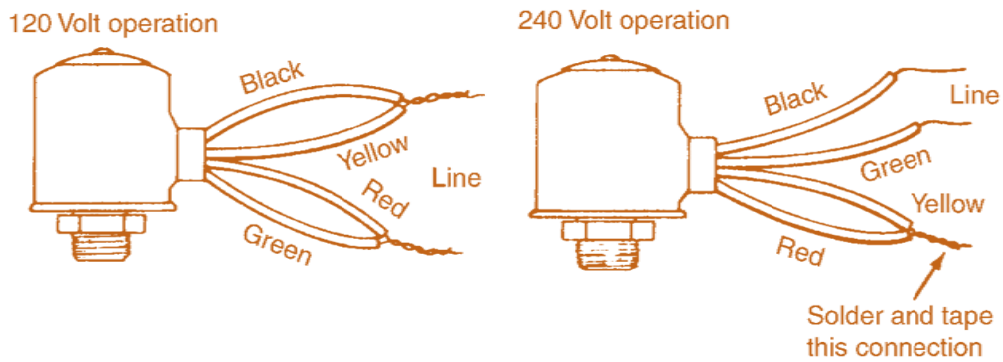

Figure 13: Solenoid valves. Note color-coded wires. (Courtesy of General Controls)

### 2.7 Thermostats

Temperature control by using thermostats is common to both heating and cooling equipment. Thermostats are used to control heating circuits that cause furnaces and boilers to operate and provide heat. Thermostats are also used to control cooling equipment and refrigeration units. Each of these purposes may have its own specially designed thermostat or may use the same one. For instance, in the home you use the same thermostat to control the furnace and the air-conditioning unit.

### 2.8 Bellows-type thermostats

On modern condensing units, low-pressure control switches are largely superseded by thermostatic control switches. A thermostatic control consists of three main parts: a bulb, a capillary tube, and a power element or switch. The bulb is attached to the evaporator in a manner that assures contact with the evaporator.

It may contain a volatile liquid, such as a refrigerant. The bulb is connected to the power element by means of a small capillary tube (see Fig. 14).

Operation of the bellows is provided by a change in temperature. Or the operation of the thermostatic control switch is such that, as the evaporator temperature increases, the bulb temperature also increases. This raises the pressure of the thermostatic liquid vapor. This, in turn, causes the bellows to expand and actuate an electrical contact. The contact closes the motor circuit, and the motor and compressor start operating. As the evaporator temperature decreases, the bulb becomes colder and the pressure decreases to the point where the bellows contracts sufficiently to open the electrical contacts, thus turning off the motor circuits. In this manner, the condensing unit is entirely automatic. Thus, it is able to produce exactly the amount of refrigeration needed to meet any normal operating condition.

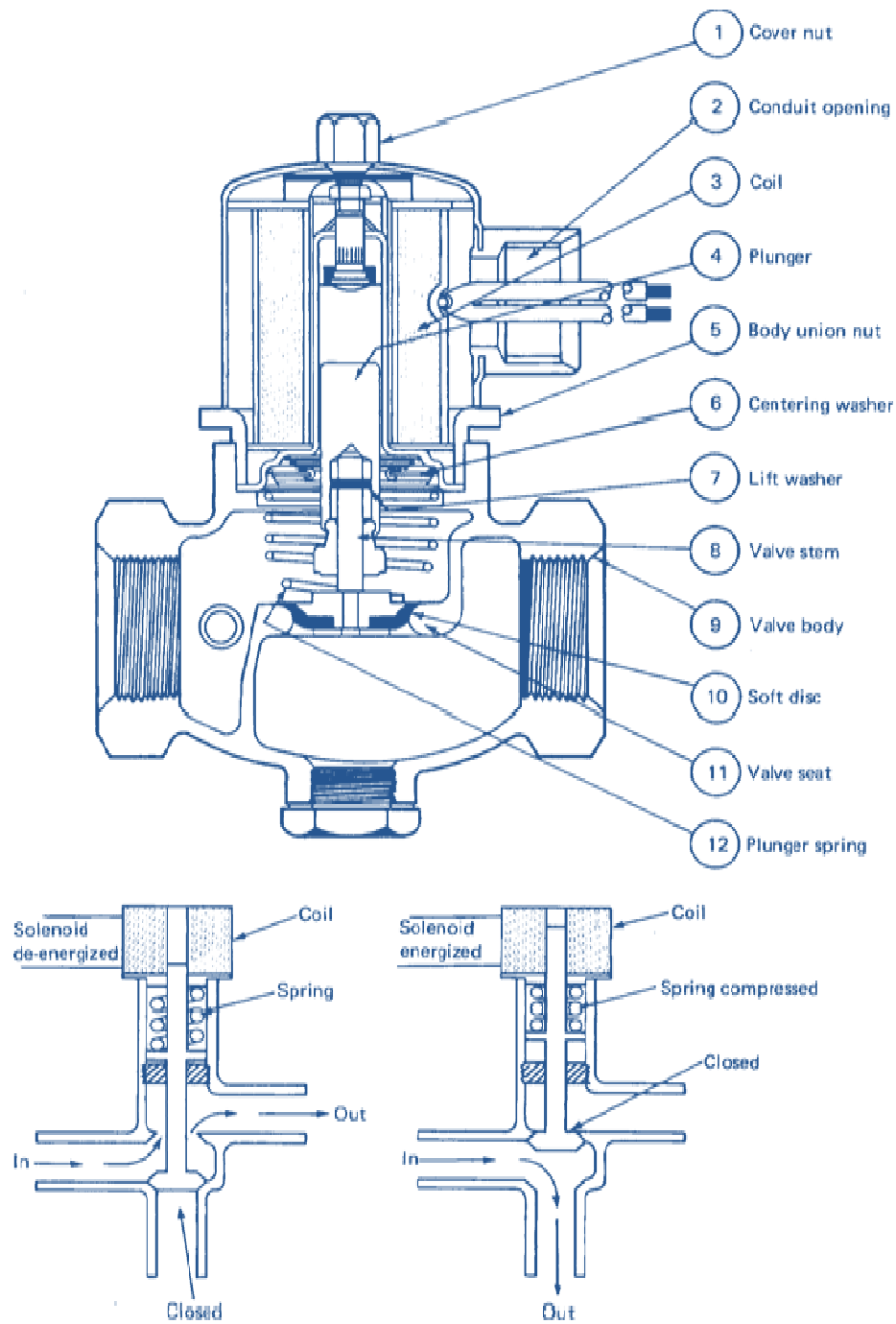

Figure 14: Solenoid used for controlling natural gas flow to a furnace. (Courtesy of Honeywell)

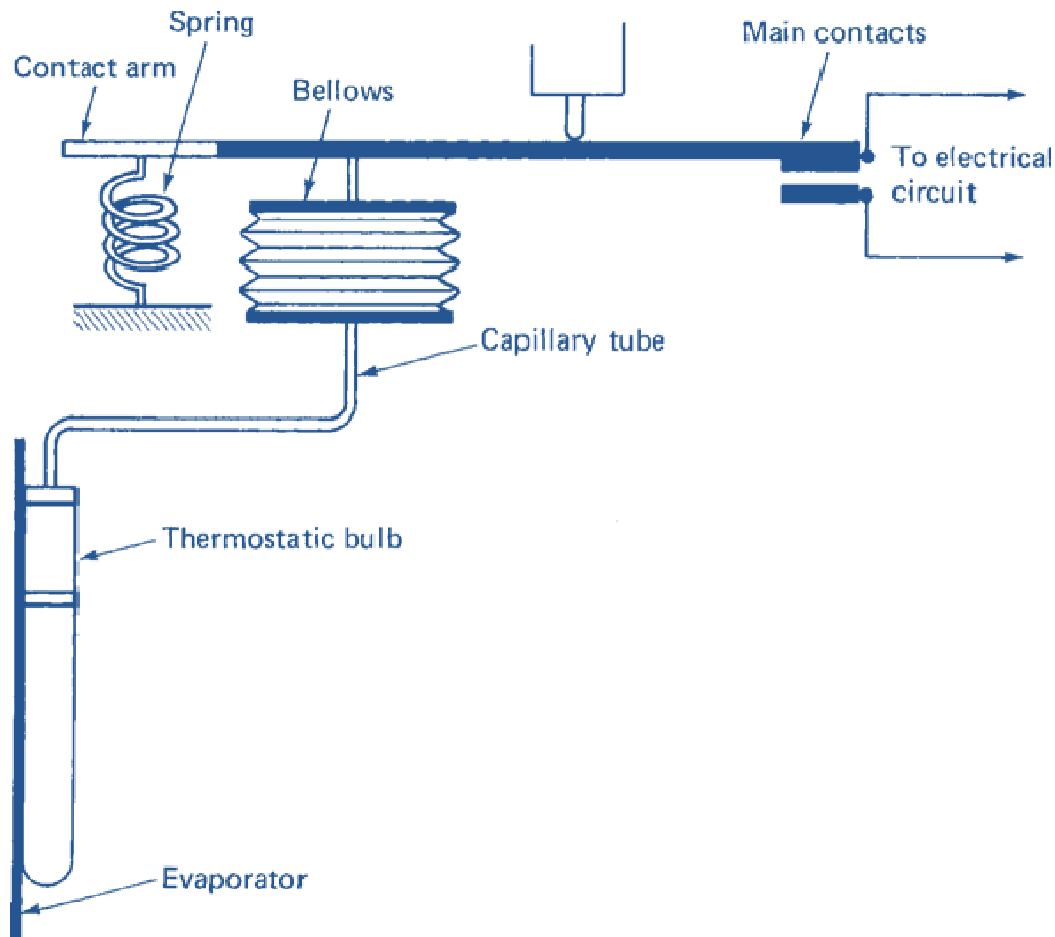

Figure 15: Bellows-type switch.

### 1.9 Bimetallic-type thermostats

Temperature changes can cause a bimetallic strip to expand or contract in step with changes in temperature. These thermostats are designed for the control of heating and cooling in air-conditioning units, refrigeration storage rooms, greenhouses, fan coils, blast coils, and similar units. This is the type used in most homes for control of the central air-conditioning and central heating system.

Figure 16 shows how the bimetallic strip thermostat works. Two metals, each having a different coefficient of expansion, are welded together to form a bimetallic unit or blade. With the blade securely anchored at one end, a circuit is formed and the contact points are closed. This allows the passage of an electric current through the closed points. Because an electric current provides heat in its passage through the bimetallic blade, the metals in the blade begin to expand. However, they expand at a different rate. The metals in the blade are so arranged that the one with a greater coefficient of expansion is placed at the bottom of

the unit. After a certain time, the operating temperature is reached and the contact points become separated. This disconnects the device from its power source.

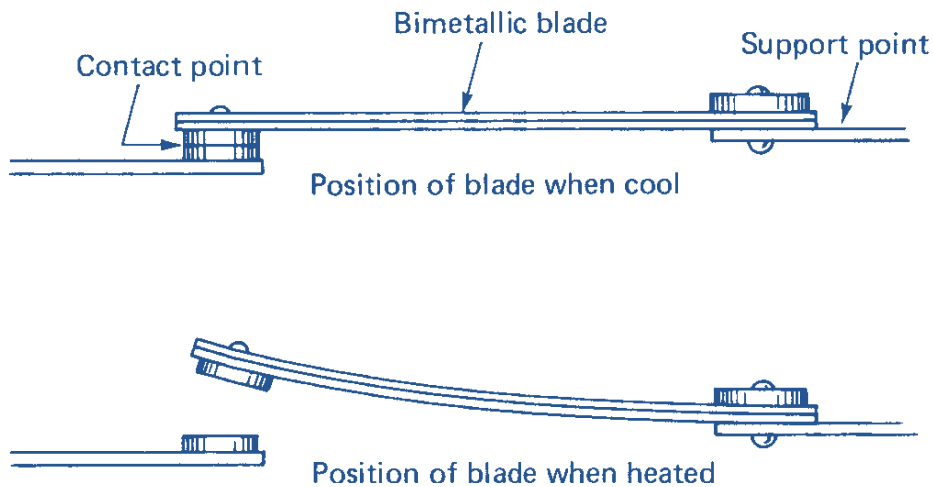

Figure 16: Bimetallic strip used in a thermostat.

After a short period, the contact blade will again become sufficiently cooled to cause the contact point to join, thus reestablishing the circuit and permitting the current again to actuate the circuit. The cycle is repeated over and over again. In this way, the bimetallic thermostat prevents the temperature from rising too high or dropping too low.

### 2.10 Heating and cooling thermostats

Some thermostats can be used for both heating and cooling. The thermostat shown in Fig. 17 is such a device. The basic thermostat element has a permanently sealed, magnetic SPDT switch. The thermostat element plugs into the sub base and contains the heat anticipation, the magnetic switching, and a room temperature thermometer. The sub base unit contains fixed cool anticipation and circuitry. This thermostat is used with 24 volts ac. In this case, the thermostat element (bimetal) does not make direct contact with the electric circuit. Instead, the expansion of the bimetal causes a magnet to move. This, in turn, causes the switch to close or open. Figure 18 shows that the bimetal is not in the electric circuit.

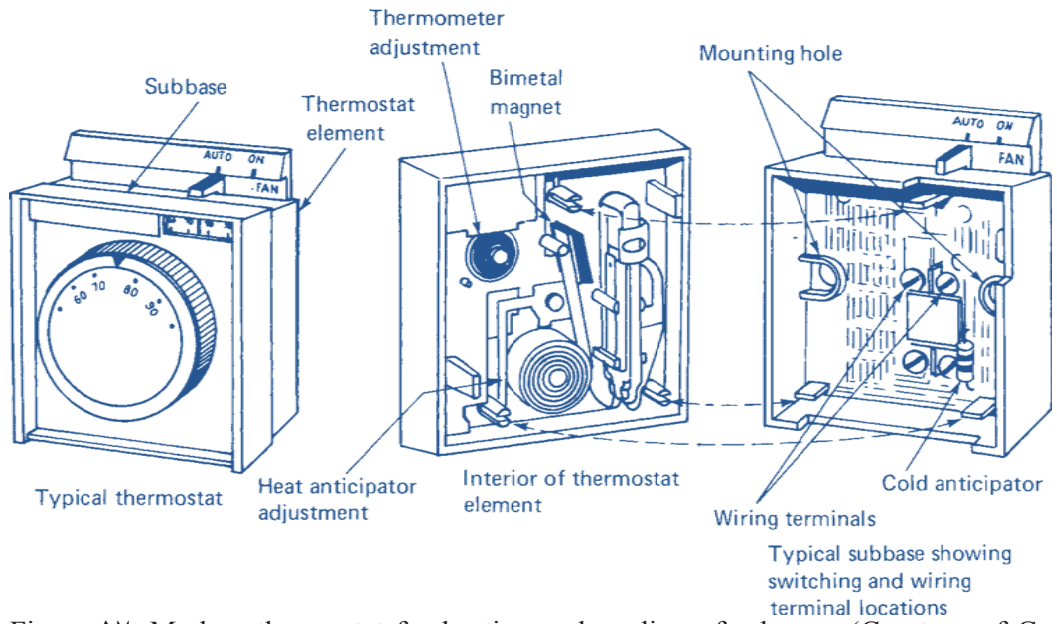
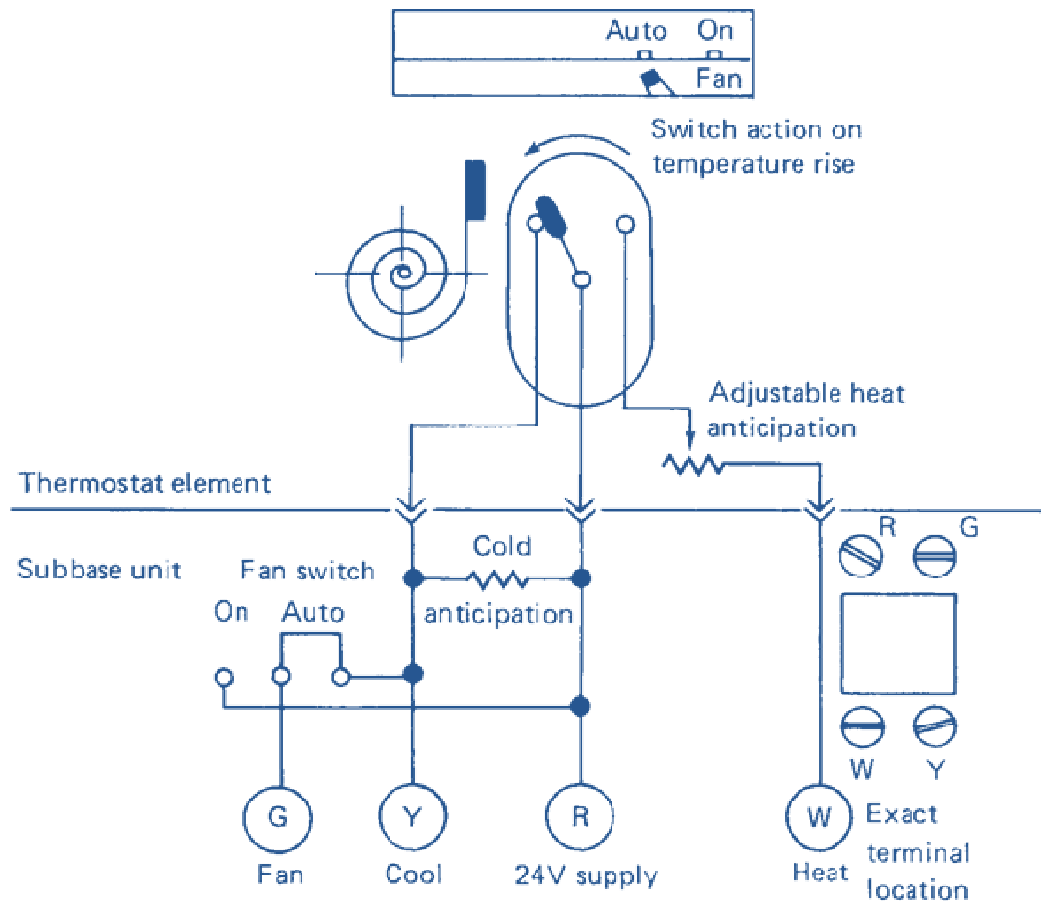

Figure 14: Modern thermostat for heating and cooling of a house. (Courtesy of General Controls)



System: Heating and cooling  
Switching: Fan—On/Auto

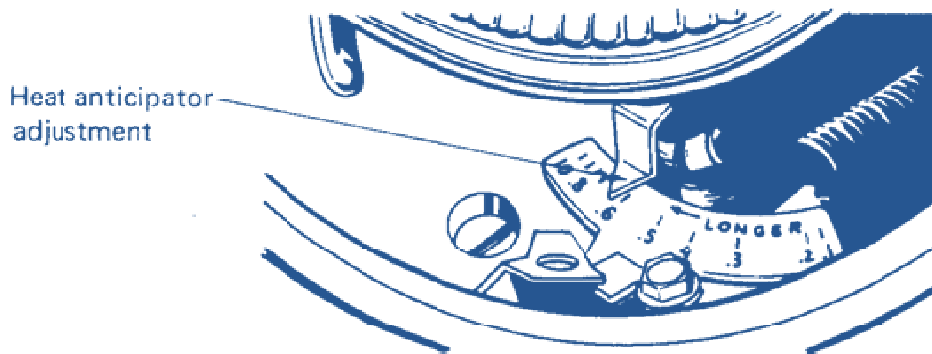

Figure 14: Wiring diagram for a thermostat.

Mercury contacts: Some thermostats use the expanding bimetal arrangement to cause a tube of mercury to move. As the mercury moves in the tube, it comes in contact with two wires inserted into the glass tube. When the mercury comes in contact with the two wires, it completes the electric circuit. This type of thermostat needs to be so arranged that the tube



of mercury is pivoted and can be moved by the expanding or contracting bimetal strip, which exerts or releases pressure on the tube of mercury.

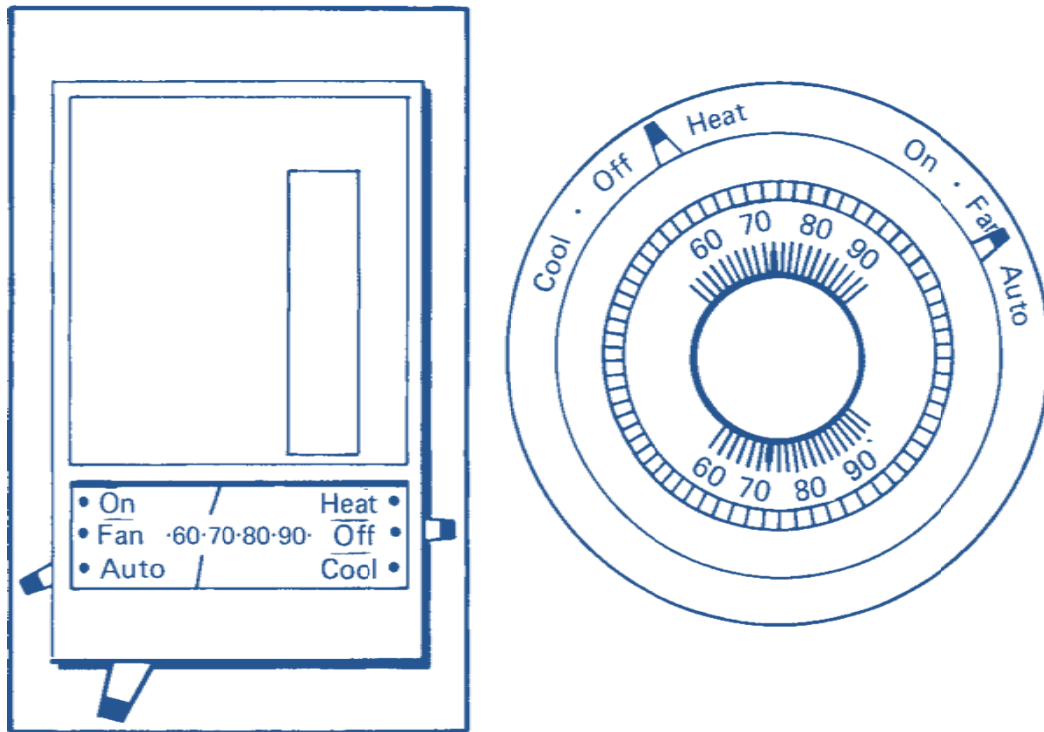

Figure 19: Thermostat for air conditioning and heating.

Thermostats used in home air-conditioning and heating systems are now equipped with mercury contacts (see Fig. 19). They are made so that the mercury contacts two wires that control the air conditioning in one position and two wires that control the heating system in the other position (see Fig. 20). The advantage of the mercury bulb type of switch is the elimination of switch contact points. Contact points are in need of constant attention. In most cases,

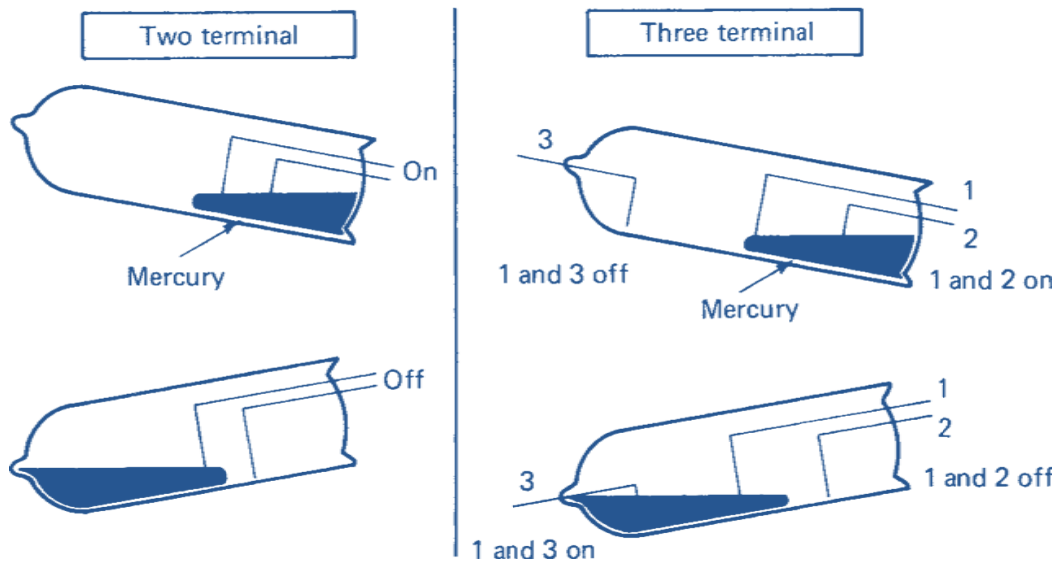

Figure 20: Mercury-switch operation.

the dust from the air will eventually cause them to function improperly. It is necessary to clean the points by running a piece of clean paper through them to remove the dust particles and arcing residue. Since the mercury type is sealed and the arcing created on make and break of the circuit simply causes the mercury to vaporize slightly and then return to a liquid state, it provides a trouble-free switching operation.

### 2.11 Microprocessor thermostats

Semiconductor technology has produced another means of more accurately controlling air-conditioning and heating systems to provide better regulated temperatures in the home, office, and business. All the external connections are the same as for any other type of thermostat.

Only the internal circuitry has changed to provide a better regulated temperature and a variety of operations that allow you to set it for any energy-saving program desired (see Fig. 21). Unless a battery is included, it does not retain the program in most instances, and the clock, if there is one on the unit, has to be reset each time the power goes off.

### 2.12 Thermostat Adjustments

In Fig. 22, a cold anticipation and a heat anticipation adjustment are placed in the thermostat circuit. The heat anticipation control is placed in series with the switch. The cold anticipation resistor is placed in shunt or parallel with the switch. Thus, when the switch is closed the shunt is shorted out.

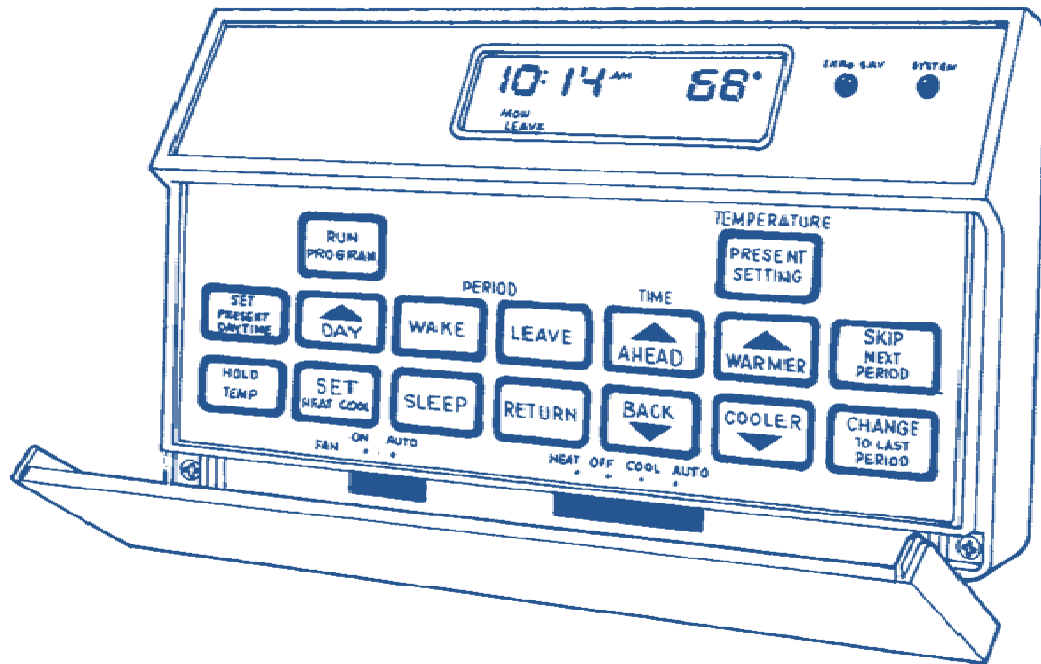

Figure 21: Microprocessor used for air-conditioning and furnace control in a home.

### 2.13 Heat anticipators

The reason for the heat anticipator is to limit the degree of swing between turning on the furnace and the temperature of the room. It is a resistance heater element that is inserted in series with the thermostat line that runs to the heat contactor coil. Once the thermostat contacts are closed, current flows through the resistor. This causes it to heat up. The heat generated by the resistor causes the thermostat to open slightly before the desired room temperature is reached by the heating system. This allows the heat in the plenum of the furnace to continue to heat the room. Thus, the resistor aids the thermostat in anticipating the amount of heat that will be provided to the room by using the heat already produced in the plenum.

### 2.14 Cold anticipators

The cold anticipator is a fixed resistor and is not adjustable. It heats the bimetallic coil that operates the points whenever the air-conditioner compressor is not on. When the compressor is on, the resistor is shorted out by the thermostat points being closed. The heating of the coil while the points are open causes it to close a little earlier than if it waited for the room to heat up sufficiently to cause it to turn on. This way the heat produced by the anticipator resistor causes the compressor to turn on a little before the thermostat would

have normally told it to do so. By turning it on before the room has reached the selected temperature, the anticipator causes the temperature swing in the room to be reduced and makes it more comfortable.

### 2.10 Switches of Many Types

Many types of switches are used to limit the amount of heat produced in a furnace.

The upper limit has to be controlled so that the furnace does not cause fires by overheating.

Limit switches take various forms depending on the manufacturer.

However, Fig. 22 shows a typical switch and how it works. This is a combination of fan and limit controller that combines the functions of a fan controller and a limit controller in a single unit. One sensing element is used for both controls.

Combination controllers are wired in much the same way as individual controls.

These combined controls can be used on line voltage, low voltage, or self-energizing millivolt systems.

Figure 23 shows the fluid-filled type of capillary tube used in a limit switch. The one shown in Fig. 22 is the bimetal type that twists as it heats up, causing the control unit to move. These limit switches are placed in the plenum of the furnace to control when the fan goes on and off; when the plenum has reached the desired temperature, it turns off the solenoid and shuts off the flow of natural gas to the burner. Limit switches of a slightly different configuration are also used for electrical strip heaters. They may also be of the low voltage (24 volts) or line voltage type.

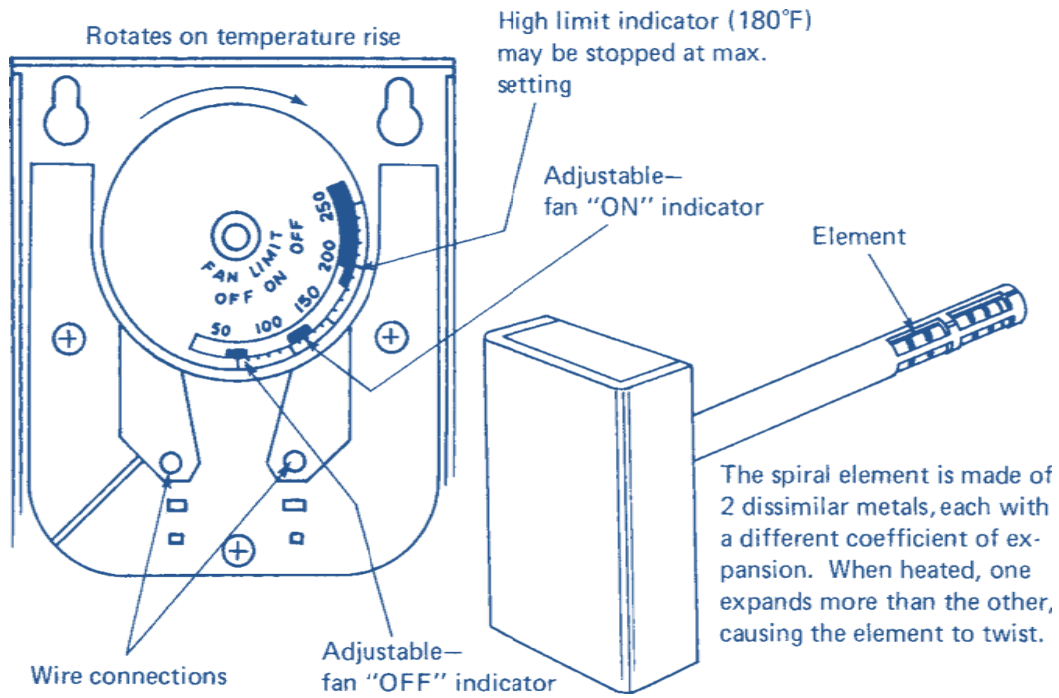

Figure 22: Combination fan and limit controller (fluid filled type).

### 2.16 Pressure Control Switches

One safety feature for air-conditioning units with a compressor and condenser is a pressure-controlled switch. This switch is wired into the circuit to protect the system in case the system develops a leak. If a leak develops, it is possible to draw in moisture and air and damage the whole system. If the pressure

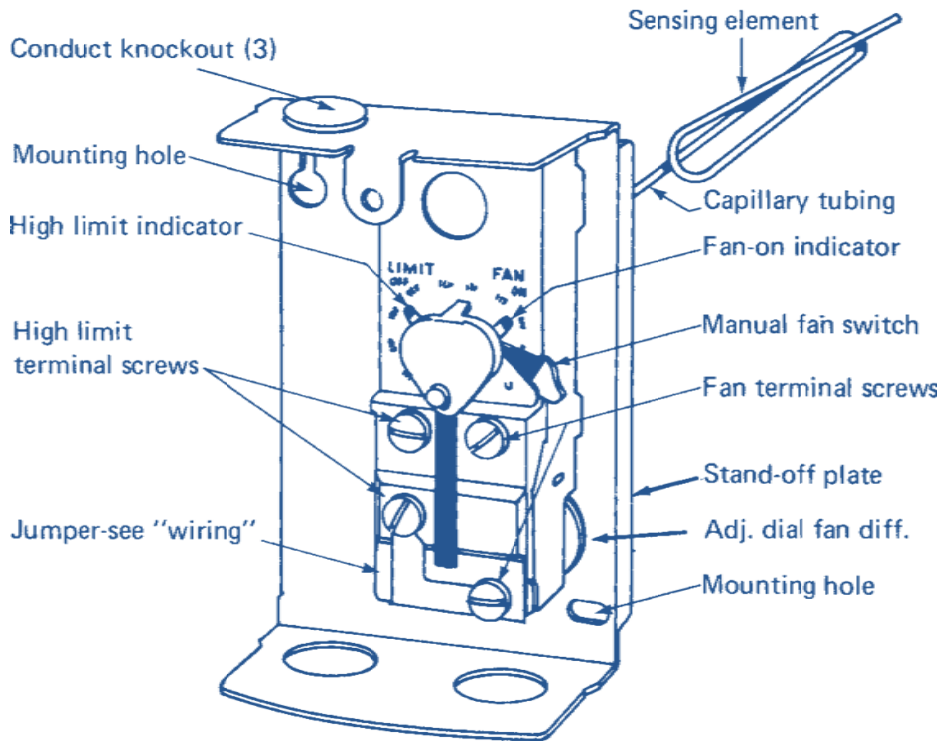

Figure 23: Combination fan and limit controller (bimetal type).

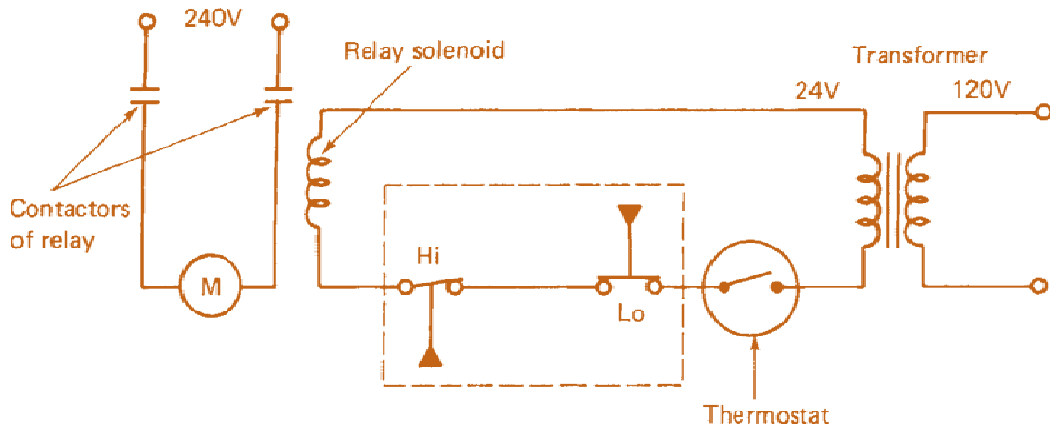

Figure 24: Pressure-operated switches control the compressor.

builds too high, it can cause a rupture of any of the joints or weaker points in the system. A low-voltage (24-volt) relay is wired into the 240-volt line that supplies the compressor motor. The relay contacts are wired into the supply line for the motor (see Fig. 24). The solenoid of the relay is wired in series with two pressure-operated switches. If the pressure builds too high, the high switch will open and cause the solenoid to de-energize. If this happens, it causes the contacts of the relay to open. This removes power from the compressor motor. If the low-pressure switch opens, it will do the same thing. This way the compressor is protected from both high and low pressure, causing damage to the system.

Both manual and automatic controls are available. Automatic controls reset when the pressure is stabilized in the system. If it is not stabilized, it will again turn the system off and keep recycling until it reaches the design pressure.

### 4.17 Water Tower Controls

Temperature controls for refrigerating service are designed to maintain adequate head pressure with evaporative condensers and cooling towers. Low refrigerant head pressure, caused by abnormally low cooling water temperature, reduces the capacity of the refrigeration system.

Two systems of control for mechanical and atmospheric draft towers and evaporative condensers are shown in Figs. 40 and 46. The control opens the contacts when the temperature drops. These contacts are wired in series with the fan motor. Or they can be wired to the pilot of a fan-motor controller. Opening the contacts stops the fan when the cooling water temperature falls to a predetermined minimum value. This value corresponds to the minimum head pressure for proper operation. In the control system shown in Fig. 46, the contacts close on a temperature drop and are wired in series with a normally closed motorized valve or a solenoid valve. The contacts open the valve when low cooling temperature occurs. The cooling water then flows through a low header in the atmospheric tower. This reduces its cooling effect and the head pressure increases.

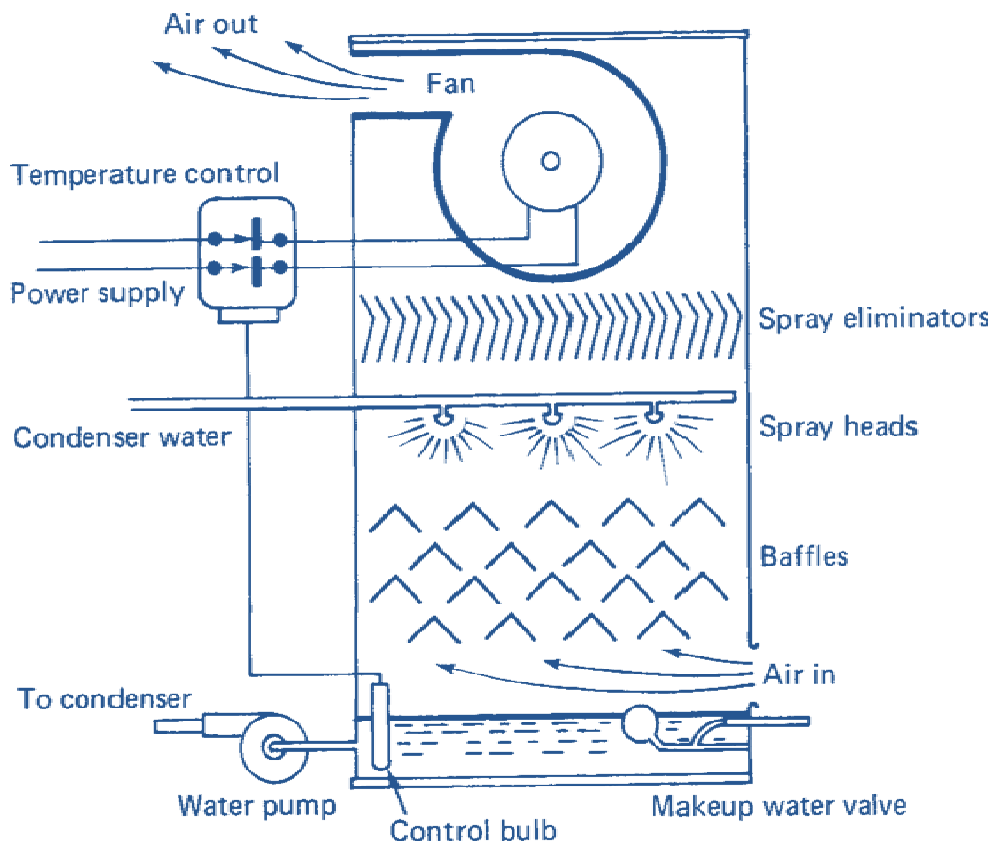

Figure 20: Cooling tower with forced-air draft.



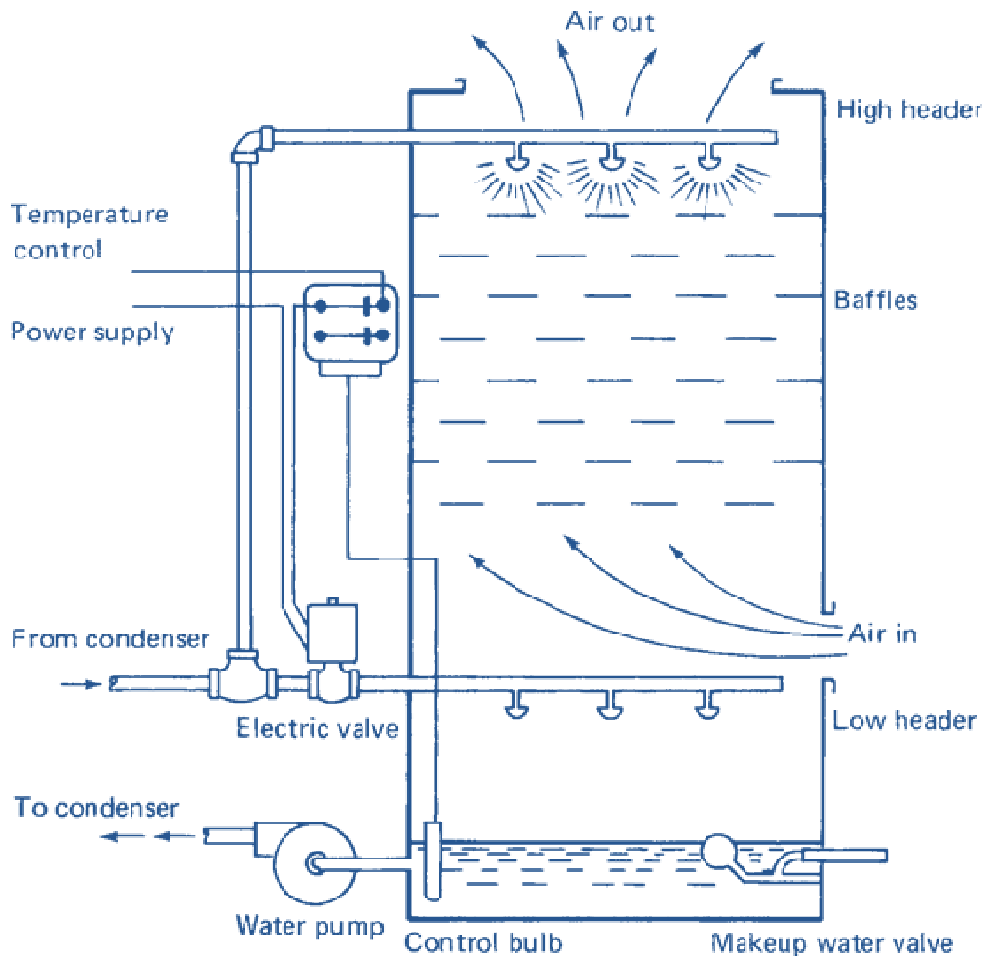

Figure 26: Cooling tower with atmospheric draft cooling.

Float switches are used to control the level of water in the cooling tower. Automatic float switches provide automatic control for motors operating tank or sump pumps. They are built in several styles and can be supplied with several types of accessories that provide rod or chain operation and either wall or floor mounting. A sensor system may also be used. There are hundreds of sensor types. They usually sense the level of water by using two probes. When the water contacts the probes, it causes a small electric current (at low voltages) to flow and energize a solenoid or relay that in turn causes the water to be turned off.

When the level of water is below the two probes and a complete circuit is not available, the normally closed relay contacts are closed by de-energizing the relay. This causes the water solenoid to be energized. This allows makeup water to flow into the cooling tower until it reaches the point where the probes are immersed in water and the cycle is repeated.

## REFERENCES:

١. Rex Miller and Mark R. Miller, (٢٠٠٧). Electricity and Electronics for HVAC. McGraw-Hill Company.
٢. ASHRAE (١٩٩٧). HVAC Handbook Fundamental
٣. Stephen L. Herman, Bennie L. Sparkman, (٢٠٠٦). Electricity & Controls for HVAC/R. Delmar, Cengage Learning
٤. Roger W. Haines and Douglas C. Hittle (٢٠٠٦). Control Systems For Heating, Ventilating, and Air Conditioning Sixth Edition. Springer Science Business Media, Inc.